

***ENGLISH
LANGUAGE
DEVELOPMENT
ASSESSMENT***

***TEACHER SUPPORT
MATERIALS***

**Spring 2015
Grades 1-2**



ENGLISH LANGUAGE DEVELOPMENT ASSESSMENT (ELDA)

Developed by

The English Language Development Assessment (ELDA)
State Collaborative on Assessment and Student Standards (SCASS)

With operational support provided by

Measurement Incorporated

The ELDA is a product of the collaboration among ELDA (formerly ELL) SCASS member states, the Council of Chief State School Officers (CCSSO), and the U.S. Department of Education. Funding to support development of this assessment has come from ELL SCASS member states, CCSSO, and the U.S. Department of Education through a Section 6112 Enhanced Assessment Instruments grant.

The Council would like to acknowledge and express its gratitude to the ELL and ELDA SCASS members [current and former] who have dedicated their time and insights to ensure that ELDA not only meets the requirements of the law, but also meets the needs of students and teachers. The current ELDA SCASS member states whose staff continues to contribute significantly to the operation and development of the ELDA include:

Arkansas
Iowa

Louisiana
Nebraska
South Carolina

Tennessee
West Virginia

COUNCIL OF CHIEF STATE SCHOOL OFFICERS

Terry Holliday (Kentucky), President

Chris Minnich, Executive Director

Scott Norton, Strategic Initiative Director, Standards, Assessment, & Accountability

Sharon M. Sáez, ELDA Coordinator

State Collaborative on Assessment and Student Standards (SCASS)

Council of Chief State School Officers

One Massachusetts Avenue, NW

Suite 700

Washington, D.C. 20001-1431

Copyright© 2014 by the Council of Chief State School Officers. All rights reserved.

ELDA Teacher Support Materials

R01

1.2 Phonics: Demonstrate knowledge of letter recognition and letter-sound correspondence.

Teacher Directions: Show students the alphabet printed in random order.

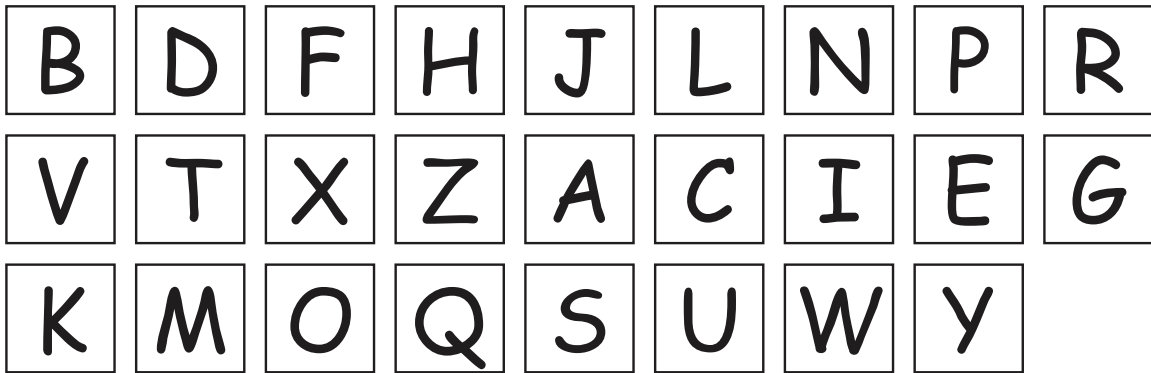

1. Teacher asks student to point to specific letters. Do this 5 – 10 times to determine if student is capable of proceeding to letter names and sounds.
2. Teacher asks student “What letter is this?” Teacher points to each letter, first upper case, then lower case, noting correct responses on record sheet.

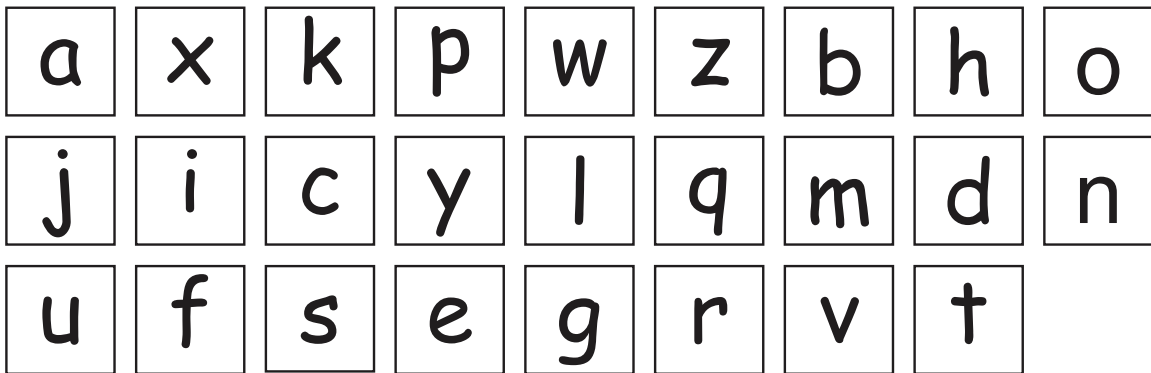

3. Teacher asks student, “What sound does this letter make?”

*The name of the letter and the sound can be tested simultaneously.

4. Teacher records student’s correct responses on record sheet.

ELDA Teacher Support Materials

R01

1.2 Phonics: Demonstrate knowledge of letter recognition and letter-sound correspondence.

Record Sheet

Upper Case Letters	Identifies Letter (+ /-)	Lower Case Letters	Identifies Letter (+ / -)	Identifies Letter Sound (+ /-)
B		a		
D		x		
F		k		
H		p		
J		w		
L		z		
N		b		
P		h		
R		o		
V		j		
T		i		
X		c		
Z		y		
A		l		
C		q		
I		m		
E		d		
G		n		
K		u		
M		f		
O		s		
Q		e		
S		g		
U		r		
W		v		
Y		t		

ELDA Teacher Support Materials

R02

1.1 Phonemic awareness: Recognize sounds, combinations of sounds, and meaningful differences between sounds in context.

Score Point 1 - Initial Sounds

The teacher points to the picture of the tub and says “tub” and asks the student to repeat the word. The teacher points to each picture and says, “tub – car, tub – fox, tub – ten.”

The teacher asks the student to circle the picture that begins or starts with the same sound as tub.

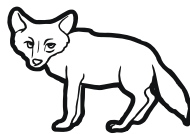
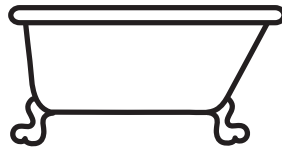

10

ELDA Teacher Support Materials

R02

1.1 Phonemic awareness: Recognize sounds, combinations of sounds, and meaningful differences between sounds in context.

Score Point 1 - Initial Sounds

The teacher points to the picture of the net and says “net” and asks the student to repeat the word. The teacher points to each picture and says, “net – nut, net – cat, net – pen.”

The teacher asks the student to circle the picture that begins or starts with the same sound as net.

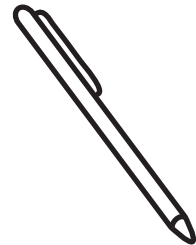
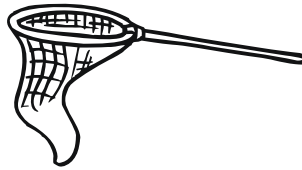

ELDA Teacher Support Materials

R02

1.1 Phonemic awareness: Recognize sounds, combinations of sounds, and meaningful differences between sounds in context.

Score Point 1 - Initial Sounds

The teacher points to the picture of the sun and says “sun” and asks the student to repeat the word. The teacher points to each picture and says, “sun – mop, sun – saw, sun – log.”

The teacher asks the student to circle the picture that begins or starts with the same sound as sun.

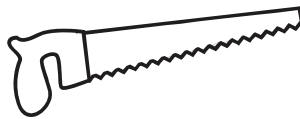
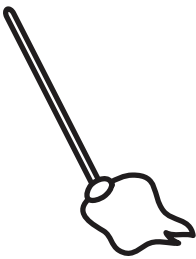
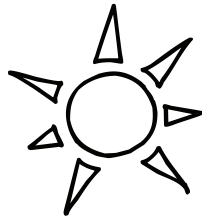

ELDA Teacher Support Materials

R02

1.1 Phonemic awareness: Recognize sounds, combinations of sounds, and meaningful differences between sounds in context.

Score Point 1 - Ending Sounds

The teacher says, “Now we are going to listen for words that end with the same sound like cup and top; say cup and top.” The teacher points to each picture as she says each word.

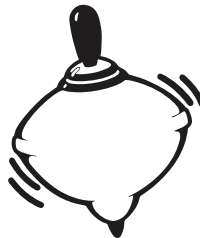

ELDA Teacher Support Materials

R02

1.1 Phonemic awareness: Recognize sounds, combinations of sounds, and meaningful differences between sounds in context.

Score Point 1 - Ending Sounds

The teacher points to the picture of the pot and says “pot” and asks the student to repeat the word. The teacher points to each picture and says, “pot – key, pot – car, pot – rat.”

The teacher asks the student to circle the picture that ends with the same sound as pot.



ELDA Teacher Support Materials

R02

1.1 Phonemic awareness: Recognize sounds, combinations of sounds, and meaningful differences between sounds in context.

Score Point 1 - Ending Sounds

The teacher points to the picture of the man and says “man” and asks the student to repeat the word. The teacher points to each picture and says, “man – pen, man – bat, man – cow.”

The teacher asks the student to circle the picture that ends with the same sound as man.

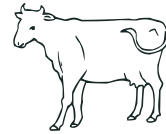
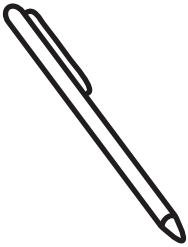
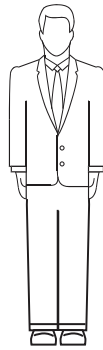

ELDA Teacher Support Materials

R02

1.1 Phonemic awareness: Recognize sounds, combinations of sounds, and meaningful differences between sounds in context.

Score Point 1 - Ending Sounds

The teacher points to the picture of the mug and says “mug” and asks the student to repeat the word. The teacher points to each picture and says, “mug – rat, mug – rug, mug – mop.”

The teacher asks the student to circle the picture that ends with the same sound as mug.

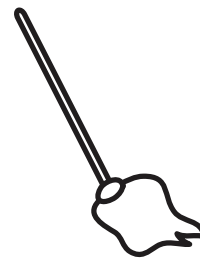
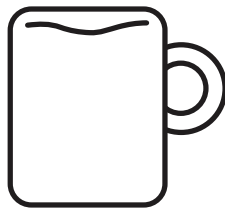

ELDA Teacher Support Materials

R02

1.1 Phonemic awareness: Recognize sounds, combinations of sounds, and meaningful differences between sounds in context.

Score Point 1 - Short Vowel

The teacher says, “Now we are going to listen for words that have the same sound in the middle like man and bat; say man and bat.” The teacher points to each picture as she says each word.

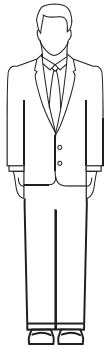

ELDA Teacher Support Materials

R02

1.1 Phonemic awareness: Recognize sounds, combinations of sounds, and meaningful differences between sounds in context.

Score Point 1 - Short Vowel

The teacher points to the picture of the van and says “van” and asks the student to repeat the word. The teacher points to each picture and says, “van – bed, van – dog, van – map.”

The teacher asks the student to circle the picture that has the same sound in the middle as van.

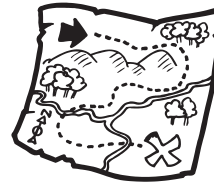
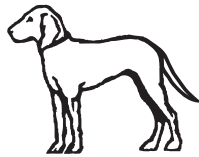

ELDA Teacher Support Materials

R02

1.1 Phonemic awareness: Recognize sounds, combinations of sounds, and meaningful differences between sounds in context.

Score Point 1 - Short Vowel

The teacher points to the picture of the six and says “six” and asks the student to repeat the word. The teacher points to each picture and says, “six – pig, six – jet, six – box.”

The teacher asks the student to circle the picture that has the same sound in the middle as six.

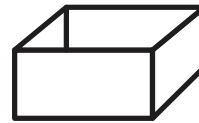
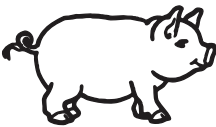

ELDA Teacher Support Materials

R03

1.3 Word Recognition: Recognize high-frequency words and common word families. Use knowledge of prefixes, suffixes, roots.

Score Point 1

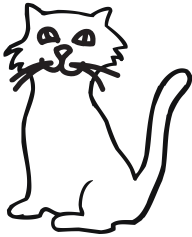

Cat



Bat



Hat

Score Point 1



Pin

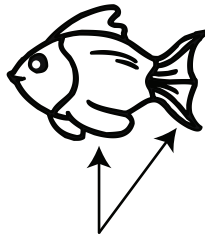

Fin

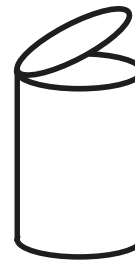

Tin

ELDA Teacher Support Materials

R03

1.3 Word Recognition: Recognize high-frequency words and common word families. Use knowledge of prefixes, suffixes, roots.

Score Point 1



Mop

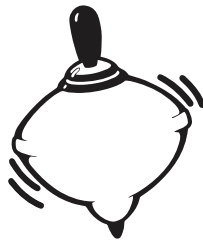

Top



Hop

Score Point 1

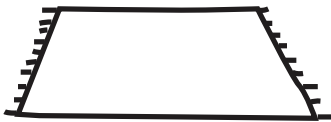

Rug

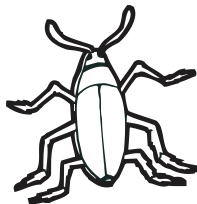

Bug



Mug

ELDA Teacher Support Materials

R03

1.3 Word Recognition: Recognize high-frequency words and common word families. Use knowledge of prefixes, suffixes, roots.

Score Point 1



Bed



Red

ELDA Teacher Support Materials

R04

1.3 Word Recognition: Recognize high-frequency words and common word families. Use knowledge of prefixes, suffixes, roots.



I'm

ELDA Teacher Support Materials

R04

1.3 Word Recognition: Recognize high-frequency words and common word families. Use knowledge of prefixes, suffixes, roots.



I'11

ELDA Teacher Support Materials

R04

1.3 Word Recognition: Recognize high-frequency words and common word families. Use knowledge of prefixes, suffixes, roots.

it's

ELDA Teacher Support Materials

R04

1.3 Word Recognition: Recognize high-frequency words and common word families. Use knowledge of prefixes, suffixes, roots.

he's

ELDA Teacher Support Materials

R04

1.3 Word Recognition: Recognize high-frequency words and common word families. Use knowledge of prefixes, suffixes, roots.

she's

ELDA Teacher Support Materials

R04

1.3 Word Recognition: Recognize high-frequency words and common word families. Use knowledge of prefixes, suffixes, roots.

isn't

ELDA Teacher Support Materials

R04

1.3 Word Recognition: Recognize high-frequency words and common word families. Use knowledge of prefixes, suffixes, roots.

can't

ELDA Teacher Support Materials

R04

1.3 Word Recognition: Recognize high-frequency words and common word families. Use knowledge of prefixes, suffixes, roots.

won't

ELDA Teacher Support Materials

R04

1.3 Word Recognition: Recognize high-frequency words and common word families. Use knowledge of prefixes, suffixes, roots.

don't

ELDA Teacher Support Materials

R04

1.3 Word Recognition: Recognize high-frequency words and common word families. Use knowledge of prefixes, suffixes, roots.

didn't

ELDA Teacher Support Materials

R10

4.1 Read and follow 1-4 step directions to complete a simple task.

Directions:

For Early Literacy Students: Teacher reads sentence(s) as student follows along. Student points or circles the answer.

For Independent Readers: Student reads statements 1-6. Student circles the response.

Model:

Raise your hand.

A



B



ELDA Teacher Support Materials

R10

4.1 Read and follow 1-4 step directions to complete a simple task.

Score Point 1

1. Line up.

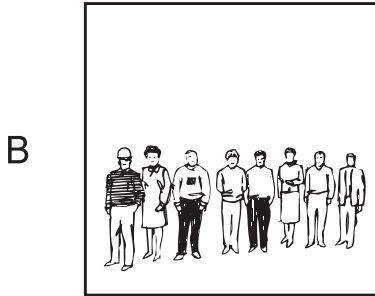

ELDA Teacher Support Materials

R10

4.1 Read and follow 1-4 step directions to complete a simple task.

Score Point 1

2. Draw a star.

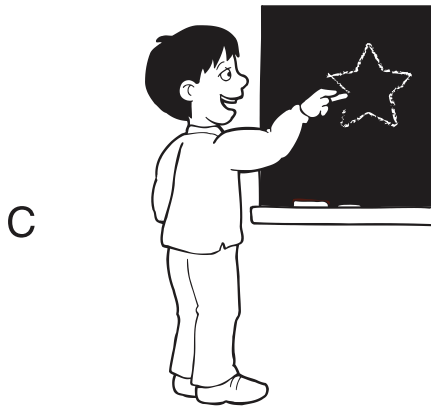
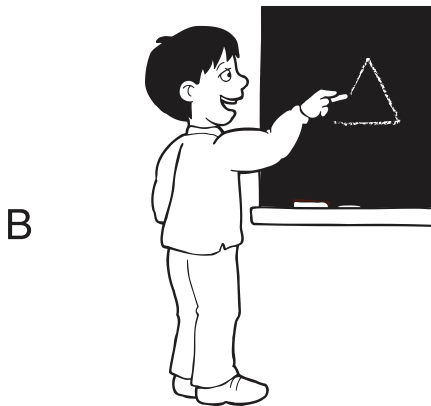
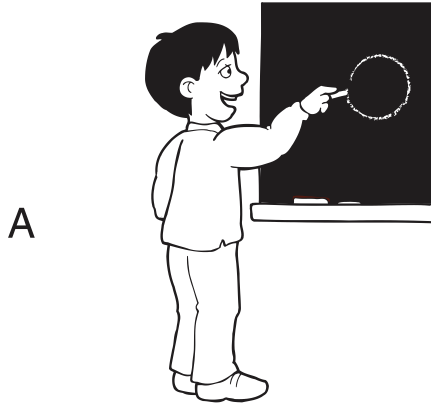

ELDA Teacher Support Materials

R10

4.1 Read and follow 1-4 step directions to complete a simple task.

Score Point 2

3. Sit down.

Raise your hand.

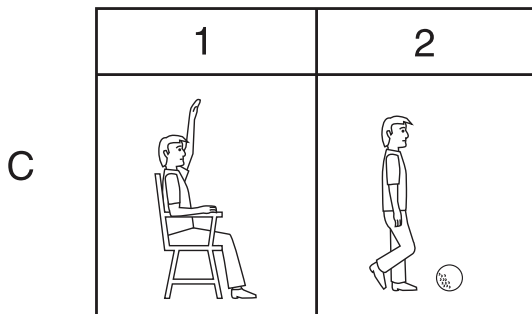
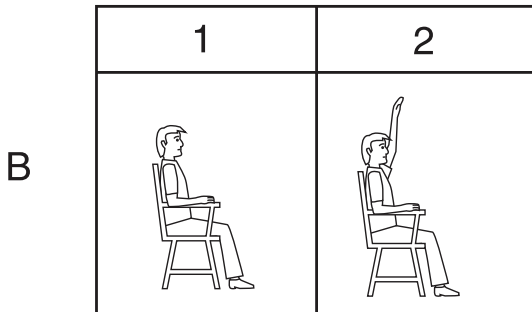
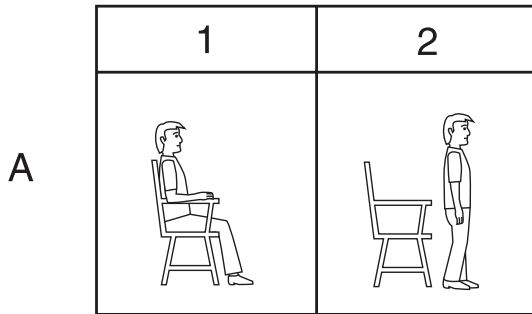

ELDA Teacher Support Materials

R10

4.1 Read and follow 1-4 step directions to complete a simple task.

Score Point 2

4. Stand up.
Go to the door.

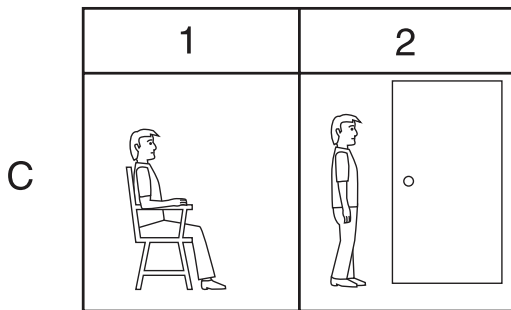
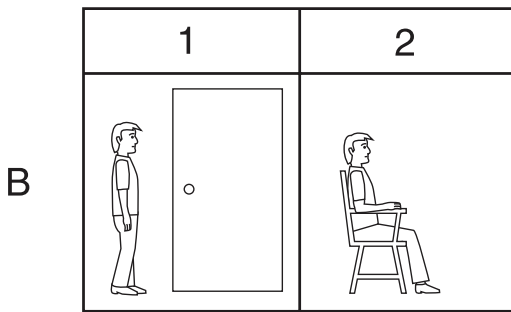
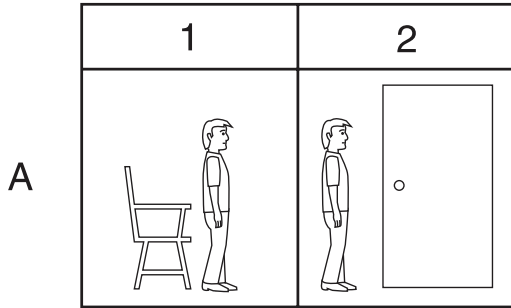

ELDA Teacher Support Materials

R10

4.1 Read and follow 1-4 step directions to complete a simple task.

Score Point 3

5. Get a book.
Take it to the table.
Sit down.

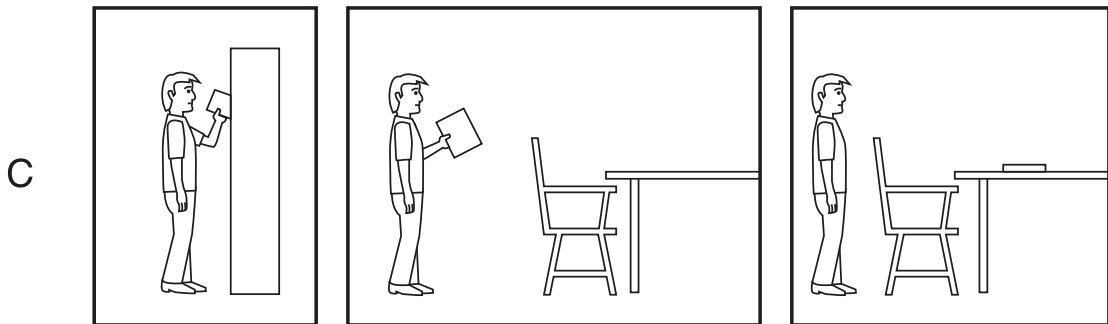
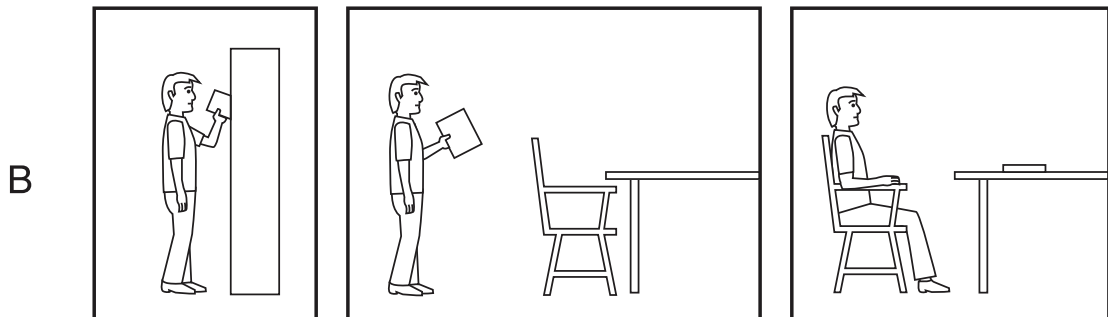
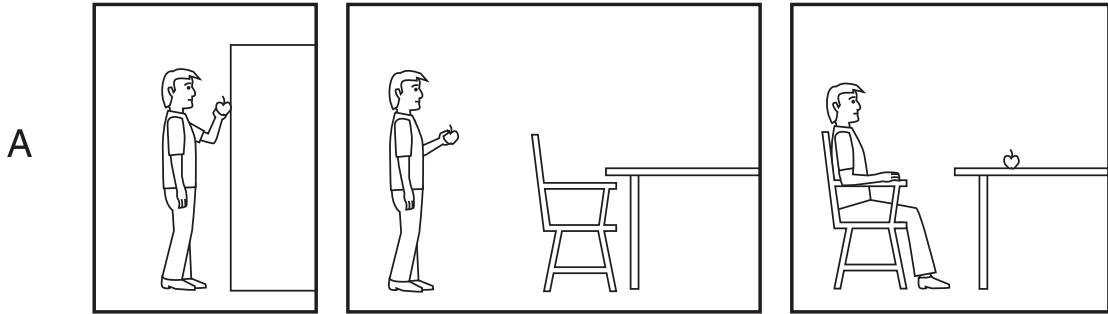

ELDA Teacher Support Materials

R10

4.1 Read and follow 1-4 step directions to complete a simple task.

Score Point 3

- Pick up the ball.
- Kick the ball.
- Put it in the box.

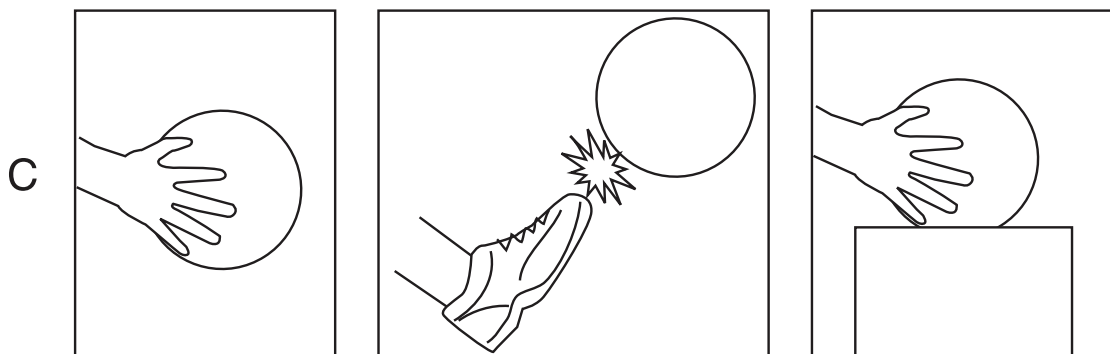
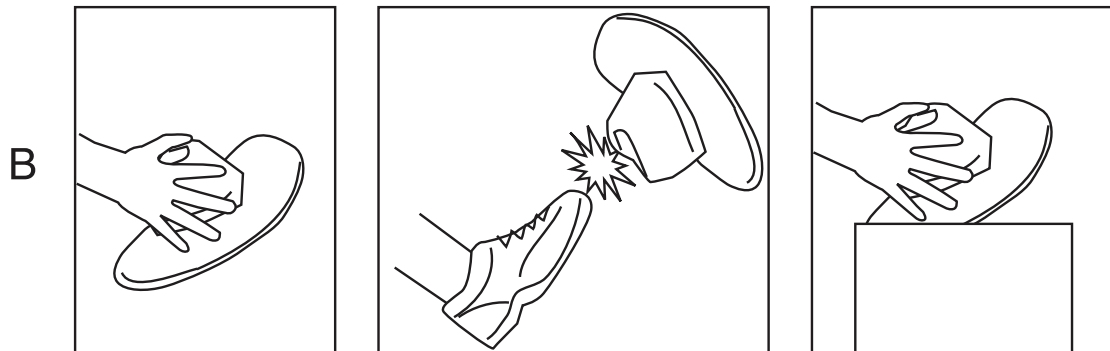
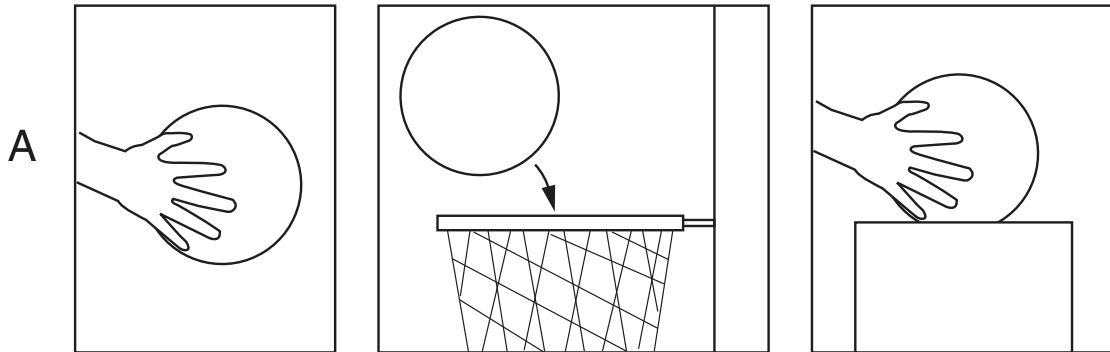



E L 1 5 T S M 2